

## Four-channel Digital Electrometer for Quadrant BPM Readout



**Features**

- Four independent integrator channels with synchronized acquisition
- Dynamic range <1 pA to 200 μA
- Integrated digitization and filtering
- Fiber-optic, RS-232 and RS-485 interfaces.
- Integrated calibration test source
- Full control provided of integration modes
- External trigger capability
- Four independent analog monitor outputs, configurable to show various analog parameters such as current, position.
- Four independent frequency monitor outputs.
- Optional high voltage output

<b>Applications</b>	<ul style="list-style-type: none"> <li>• Quadrant photodiode readout</li> <li>• Low current and charge measurement</li> <li>• Beam position monitors</li> </ul>
<b>Options</b>	<ul style="list-style-type: none"> <li>• Auxiliary HV output choices up to 3000 V</li> <li>• Alternative feedback capacitor options</li> </ul>

<b>Specifications</b>	
Operating principle	Gated integrator (charge integrating amplifier)
Integration capacitor	Dual, software selectable. Default values 100 pF and 3300 pF.
Input noise	< 200 fA rms unloaded. (1 second integration, 10 pF capacitor at ≤ 25 C ambient)
Input offset	< 10 pA , 15 to 25 C, < 3 pA typical. Offset can be removed by zero subtraction.
Stability	Output drift < 200 fA / hour at 25 +/- 1 C ambient after stabilization



**Specifications (continued)**

External accuracy	Better than 0.5% of full scale in use, integration time 500 $\mu$ sec to 1 sec, after calibration with built-in current source
Integration time	User selectable, 100 $\mu$ sec to 65 sec.
External gate	TTL 10 kohm impedance
Trigger modes	Internal (autorun), external.
Digitization	16 bit bipolar plus resolution enhancement to 20 bits
Averaging modes	Multiple conversions per integration; multiple integrations per reading to increase digital resolution up to 20 bits.
Auxiliary HV PSU	(Factory option) 0 to 1000V programmable (polarity and maximum voltage factory selectable), 1mA max. Noise and ripple < 0.1%
Power input	+24V (+/- 2V) DC, 350mA typ, 500mA max.
Controls	Two rotary switches for loop address and comms mode/ baud rate.
Displays	Status LEDs (power, device status, comms mode, data RX/TX). "HV on" LED.
Case material	Stainless steel sheet
Weight	1.64kg (3.6 lb).
Operating environment	10 to 35C (15 to 25 C recommended to reduce drift and offset) , < 70% humidity, non-condensing, vibration < 0.1g all axes (1 to 100 Hz) Vibration must be as low as possible to measure at the lower limit of the dynamic range.
Shipping and storage environment	-10 to 50C, < 80% humidity, non-condensing, vibration < 2g all axes, 1 to 100 Hz

**Interfacing**

Interfaces	RS-232 or RS-485, 8-bit ASCII. Selectable baud rate up to 115 kbos. The electrical interface can be set to be RS-232 levels, or full-duplex differential RS-485.
	Fiber-optic loop, 10 Mbit/sec serial, 9-bit asynchronous binary. Ethernet connection to host through A300 or A500 loop controllers.
Host computer	ASCII communications based on SCPI. Diagnostic host program supplied for Microsoft® .net framework. Binary DLLs available for Microsoft® .net, National Instruments™ Lab-view™, Microsoft® C++.and Linux.



**Monitor outputs**

Number	Four, independent analog voltage Four, independent frequency
Signal type	Analog voltage +/- 10V into 10 kohm. Frequency 0 to 1 MHz 5V into 50 ohm.
Software-selectable output parameter options	Current, four outputs active (relative to full scale for integration time and capacitor in use)  Independent position, outputs A and B active $X = (INA - IND) / (INA + IND)$ $Y = (INB - INC) / (INB + INC)$  Quadrant position, outputs A and B active $X = ((IN1A + INC) - (INB + IND)) / (INA + INB + INC + IND)$ $Y = ((IN1A + INB) - (INC + IND)) / (INA + INB + INC + IND)$

**Connectors**

Signal inputs	Four BNC female.												
Auxiliary HV out	SHV												
External gate in	BNC (isolated from case)												
Monitor outputs	Four Lemo coax size 00 for analog voltage Four Lemo coax size 00 for frequency												
RS-232 / RS485	Six pin mini-DIN ("PS/2") <table border="1" data-bbox="555 1186 1307 1327" style="margin-left: 40px;"> <tr> <td>1</td> <td>Tx / RS-485 Tx-</td> <td>4</td> <td>n/c</td> </tr> <tr> <td>2</td> <td>Rx / RS-485 Rx+</td> <td>5</td> <td>RS-485 Tx+</td> </tr> <tr> <td>3</td> <td>Gnd</td> <td>6</td> <td>RS-485 Rx-</td> </tr> </table>	1	Tx / RS-485 Tx-	4	n/c	2	Rx / RS-485 Rx+	5	RS-485 Tx+	3	Gnd	6	RS-485 Rx-
1	Tx / RS-485 Tx-	4	n/c										
2	Rx / RS-485 Rx+	5	RS-485 Tx+										
3	Gnd	6	RS-485 Rx-										
Fiber optics	TX & RX ST bayonet, suitable for 1mm plastic fiber or 200 µm HCS fiber.												
Power in	2.1mm threaded jack. Mates with Switchcraft S761K or equivalent.												
Ground	M3 threaded stud												

**Ordering information**

I404	I404 four channel electrometer with user manuals, software drivers, calibration data.
-XP1000/500/200 (-XN)	Add auxiliary HV supply positive 3000 V / 2000 V / 1000 V / 500 V / 200 V (negative)
-C/x/y	Specify feedback capacitors x pF, y pF. (Default is 100pF, 3300pF.)



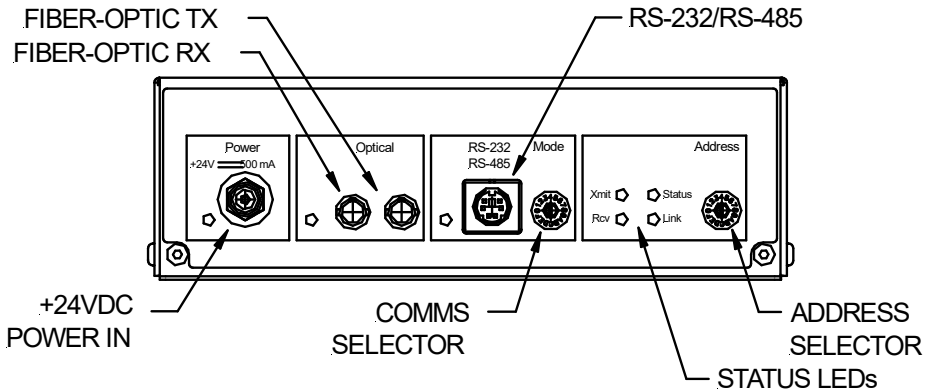
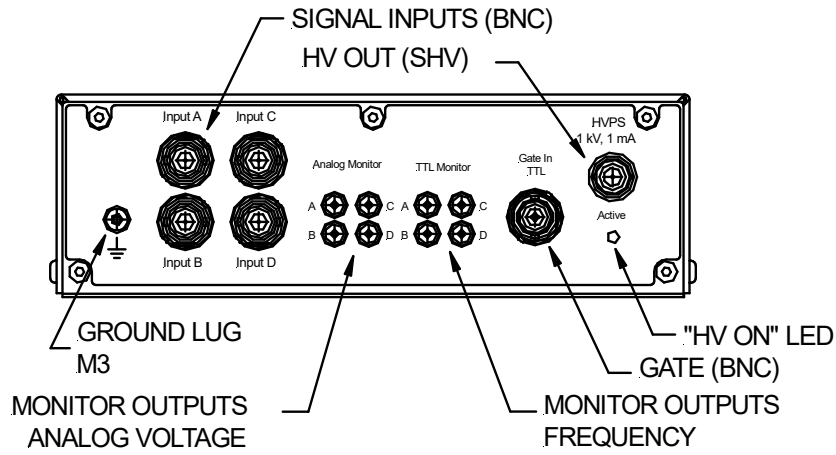

Pyramid Technical Consultants, Inc.,  
 135 Beaver, Street Suite 102  
 Waltham, MA 02452 USA  
 Tel: +1 781 402 1700 (USA),  
 +44 1273 492002 (UK)

Email: support@ptcusa.com

www.ptcusa.com

The information herein is believed accurate at time of publication, but no specific warranty is given regarding its use. All specifications are subject to change.

All trademarks acknowledged

I404\_DS\_210227



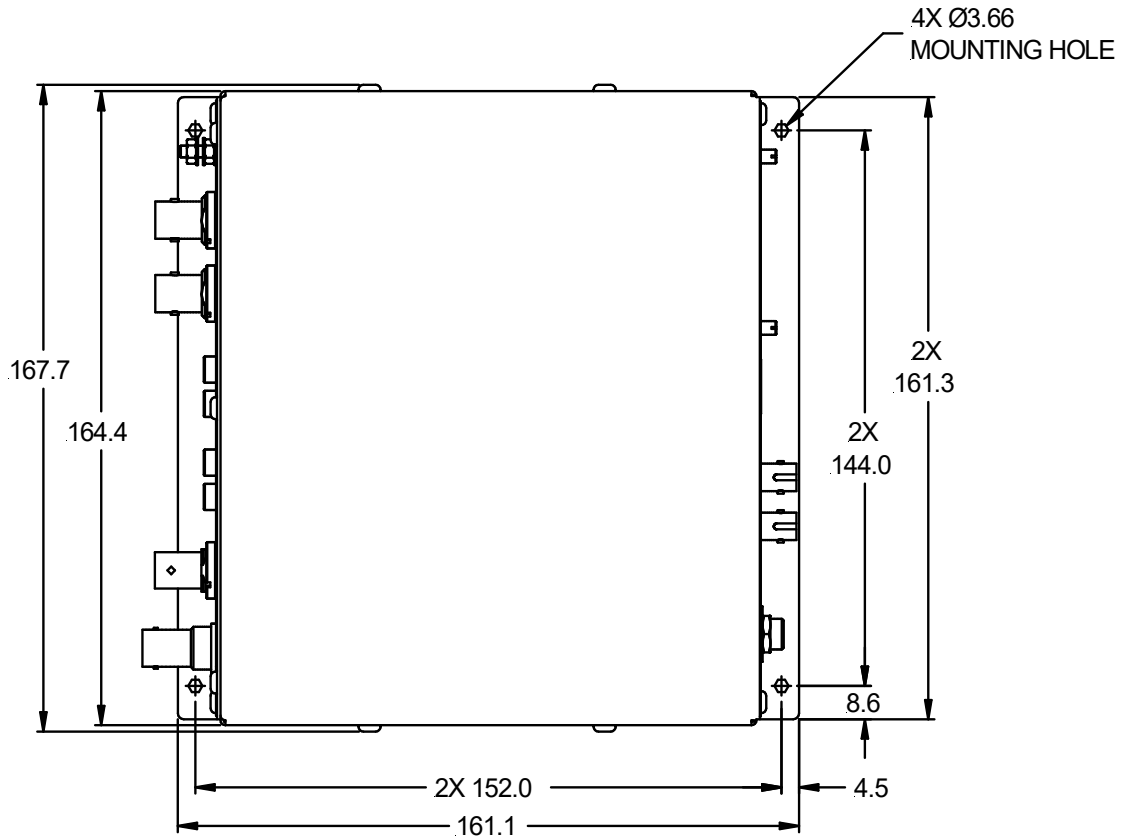

Dims mm

